

**CAUTIONS TO BE TAKEN TO ENSURE SAFETY**

- For those persons involved with the operation / service of your system, including Kawasaki Robot, they must strictly observe all safety regulations at all times. They should carefully read the Manuals and other related safety documents.
- Products described in this catalogue are general industrial robots. Therefore, if a customer wishes to use the Robot for special purposes, which might endanger operators or if the Robot has any problems, please contact us. We will be pleased to help you.
- Be careful as Photographs illustrated in this catalogue are frequently taken after removing safety fences and other safety devices stipulated in the safety regulations from the Robot operation system.



**INQUIRIES**

**KAWASAKI HEAVY INDUSTRIES, LTD.**  
[www.khi.co.jp/robot/](http://www.khi.co.jp/robot/)

Tokyo Head Office/Robot Division  
 World Trade Center Bldg., 4-1 Hamamatsu-cho 2-chome,  
 Minato-ku Tokyo 105-6116 Japan  
 E-mail: robot-pj@khi.co.jp  
 Phone : +81-3-3435-6908  
 Fax : +81-3-3437-9880

Akashi Works/Robot Division  
 1-1 Kawasaki-cho, Akashi 673-8666 Japan  
 E-mail: robot-pj@khi.co.jp  
 Phone : +81-78-921-2946  
 Fax : +81-78-923-6548

**KAWASAKI ROBOTICS (USA), INC.**  
 28059 Center Oaks Court, Wixom, MI 48393, U.S.A.  
 E-Mail : info@kri-us.com  
 www.kawasakirobot.com  
 Phone : +1-248-305-7610  
 Fax : +1-248-305-7618

**KAWASAKI ROBOTICS (UK) LTD.**  
 Units 6 & 7 Easter Court, Europa Boulevard, Westbrook  
 Warrington WA5 5ZB, United Kingdom  
 E-Mail : info@kawasakirobot.co.uk  
 www.kawasakirobot.uk.com  
 Phone : +44-1925-71-3000  
 Fax : +44-1925-71-3001

**KAWASAKI ROBOTICS GmbH.**  
 29 Sperberweg 41468 Neuss, Germany  
 E-Mail : info@kawasakirobot.de  
 www.kawasakirobot.de  
 Phone : +49-2131-34260  
 Fax : +49-2131-3426-22

**KAWASAKI MACHINE SYSTEMS KOREA, LTD.**  
 3F(307), Industrial Complex Support Bldg., 637  
 Kojan-Dong, Namdong-Gu, Incheon, 405-817 Korea  
 E-Mail : sales@kmsk.co.kr  
 www.kawasakirobot.co.kr  
 Phone : +82-32-821-6941  
 Fax : +82-32-821-6947

**Agent**

\* Materials and specifications are subject to change without notice.

**Kawasaki Robot**

Simple & friendly

**Zseries**

Japan & Asia





# Simple and friendly Kawasaki Robot

Spot welding, material handling, sealing, .....by producing many different robots to suit various applications, Kawasaki has greatly contributed to automated production lines for automotive and general industries. Kawasaki is introducing the new "Z series" heavy-duty robot, which is developed using Kawasaki's advanced technology and extensive experience in robotics. "Z series" consists of eight models and is available in floor mount "ZX" and shelf mount "ZT" configuration. Kawasaki "D" Controller is upgraded for the "Z series" robots.

## Features

### 1 Improved cycle time

The cycle time has been greatly improved by reduction of the mass and adoption of the D-controller.

### 2 Wide work envelope and low power consumption

"Z series" has wide work envelope due to long reach and small dead space. The patented Kawasaki Hybrid Link Configuration allows turning backward with low power consumption. Joint 1 travel is 360 degrees with mechanical hard stops.

### 3 Space saving and easy installation footprint

Small Footprint and integrated air piping, wiring for the valve and forklift pocket is standard for all models. This simplifies robot installation in confined areas.

### 4 Resistant configuration-IP65, IP67

IP65 for robot arm and IP67 for wrist portion. "Z series" is able to operate in the severe environment.

### 5 Upgradability

"ZX165U" can be upgraded to a faster robot or higher payload robot by adding simple hardware and software at the user site. The alteration at production site is easier, economical and exact model selection at design stage is not required.

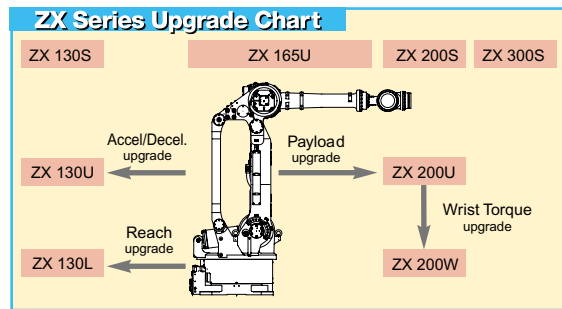
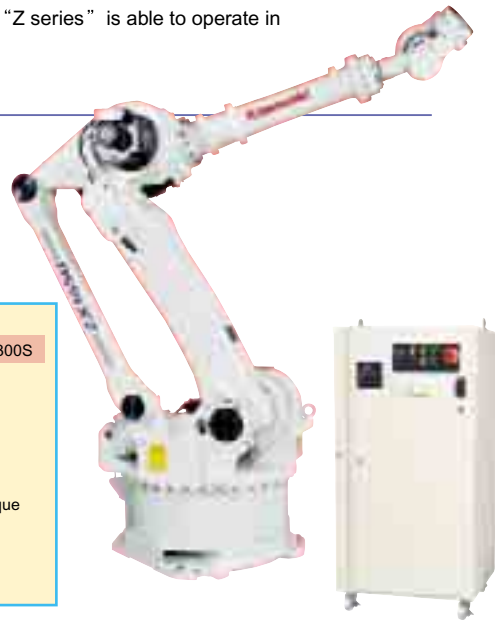

# ZT 130S/165U/200S

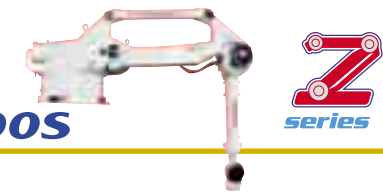

## Standard Specifications

Type	ZT130S	ZT165U	ZT200S				
Arm Type	Articulated Type						
Degrees of Freedom	6 Axes (7 Axes : Option)						
Axis Work Envelope and Max. Speed	Axis	Max. Stroke	Max. Speed	Max. Stroke	Max. Speed	Max. Stroke	Max. Speed
	JT1 : Arm rotation	± 180°	130°/s	± 180°	105°/s	± 180°	100°/s
	JT2: Arm out-in	+ 60° ~ - 75°	130°/s	+ 60° ~ - 75°	105°/s	+ 60° ~ - 75°	100°/s
	JT3: Arm up-down	+ 165° ~ - 95°	130°/s	+ 165° ~ - 95°	105°/s	+ 165° ~ - 95°	90°/s
	JT4: Wrist swivel	± 360°	180°/s	± 360°	135°/s	± 360°	120°/s
	JT5: Wrist bend	± 130°	180°/s	± 130°	135°/s	± 120°	115°/s
	JT6: Wrist twist	± 360°	280°/s	± 360°	210°/s	± 360°	180°/s
JT7: Arm traverse*	standard 2,000mm	1,000mm/s	standard 2,000mm	1,000mm/s	standard 2,000mm	1,000mm/s	
Position Repeatability	± 0.3mm						
Max. Payload	130kg	165kg	200kg				
Moment ★	JT4: Wrist swivel	735N · m	911.4N · m	1,274N · m			
	JT5: Wrist bend	735N · m	911.4N · m	1,274N · m			
	JT6: Wrist twist	421.4N · m	450.8N · m	686N · m			
Moment of Inertia ★	JT4: Wrist swivel	51.9 kg · m <sup>2</sup>	78.4 kg · m <sup>2</sup>	117.6 kg · m <sup>2</sup>			
	JT5: Wrist bend	51.94 kg · m <sup>2</sup>	78.4 kg · m <sup>2</sup>	117.6 kg · m <sup>2</sup>			
	JT6: Wrist twist	27.44 kg · m <sup>2</sup>	40.18 kg · m <sup>2</sup>	63.7 kg · m <sup>2</sup>			
Mass	1,550kg	1,550kg	1,600kg				
Mounting	Shelf						
Integrated function	Air Piping (12mm dia. x 2), Wiring for Solenoid Valve for Grippers (DC24V)						
Option	Mechanical Hard Stop JT1/JT2/JT3, End Stroke Limit Switch JT1/JT2/JT3, Special Color, Traversing Track, Internal Wiring for End Effector Double Solenoid Valve 1/2, Single Solenoid Valve 1/2, Double Sol.1 + Single Sol.1, FRL unit, Internal Hoses of Cooling Water for Welding Gun						
Color	Munsell 10GY9/1 equivalent						

★ In case of using the face plate which is supported by proper bolts and pins.

## Motion Range & Dimensions

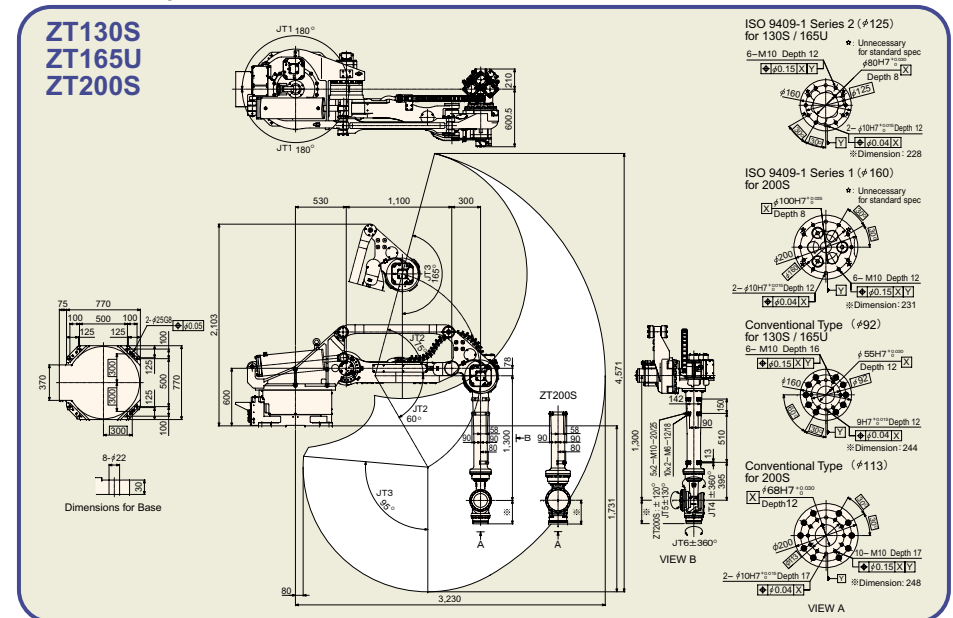



# D Controller D42

## • Features

### 1 Ergonomic Operation

#### •User Friendly Teach Pendant

The ergonomically designed, "highly responsive," key arrangement is developed through the research based on finger movement of the operator. With a 6.4-inch (170 mm) TFT color LCD screen and a large, easy-to-read touch panel, the teach pendant provides a comfortable operating environment.



**Teaching screen**  
Simple teaching can be performed by 'single touch' screen selection.

Screen selection and operation is compatible with controllers of previous generations. Using Kawasaki's own editing menus enable robot teaching very quickly and effectively.

#### Teach pendant

Incorporates a 6.4-inch (170 mm) TFT color LCD screen with a large and easy-to-read touch panel.

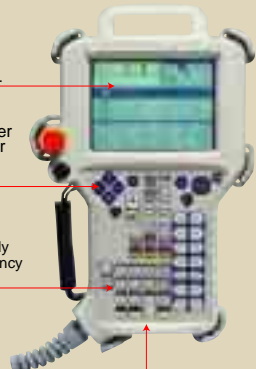

Cross arrangement of cursor keys allow easier operation with a similar feeling of TV game-controller.

Hard keys are strategically placed, achieving frequency of operation.

A 3-position Deadman switch is provided.

### 2 Ergonomic Functions

Various software is provided that is compatible with a number of applications such as handling, palletizing, spot welding, servo welding, high performance vision and arc welding.

In addition, the high level 'AS' programming language gives access to an extensive range of commands enabling a much higher level of sophistication for both robot motion and system process control.

### 3 High Performance

Processing power is provided by high-speed 64bit RISC dual processors. Operational performance, cycle time and path precision has been improved by the utilisation of a fully digital servo system. In addition, system faults have been kept to a minimum by the use of collision detection/stopping and path replay retention after an emergency stop.



### 4 Simple System Upgrades\*

\*Refer to the diagram on the page on the right

#### •Peripheral Device Control

Interfacing to peripherals is achieved by the use of standard I/O connections as well as a number of fieldbuses such as Interbus, CC-Link and DeviceNet etc. Connection to peripherals is straightforward and offers system flexibility.

In addition, an advanced integrated system can be created at minimal cost through use of K-Logic, an internal PLC with a peripheral control sequencer.

#### •Network

The controller is also compatible with network communication via Ethernet allowing data communication with a host computer and program up-loading / down-loading to be performed with great ease. In addition, a Web server feature enables analysis of the robot's status via an intranet / Internet connection to be achieved.

#### •Multiple-Axes Control

With a 6-axis unit, a maximum of 2 axes can be added within the existing control cabinet. The addition of 3 or more axes (more than 9 axes including the manipulator unit) can be performed with SSCNET-compatible motors. A multi-axis system that matches the customer's need can be easily achieved.

### 5 Ease of Maintenance

A reduction in internal wiring and the incorporation of modular component assemblies simplifies maintenance and reduces the time for repair or replacement.

In addition, maintenance support features such as 'Data Storage' offer support in identification of the cause when a problem occurs. Maintenance software support features display recovery procedures when a fault occurs, and a Web server provides the potential for remote diagnosis to be utilized.

## • Specifications

		Standard	Option
Model		D42	
Structure		Self-Standing Main Enclosure	
Number of Controlled Axes		6 Axes	Max. 16 Axes (Please contact us when using 7 Axes or more.)
Servo Motor		AC Servo Motor	
Position Detector		Absolute Encoder	
Drive System		Full Digital Servo System	
Programming		Block Teaching or AS Language	
Coordinate Systems		Joint, Base, Tool	Fixed Tool Point
Types of Motion Control		Joint, Linear, Circular Interpolated Motion	
General Purpose Signals	External Operation Signals	External Motor Power Off, External Hold	
	Input Signals	32 Channels (Includes Dedicated Signals)	64/96/128 Channels (Includes Dedicated Signals)
	Output Signals	32 Channels (Includes Dedicated Signals)	64/96/128 Channels (Includes Dedicated Signals)
Memory Capacity		1MB (Includes System Memory): Approx. 5,000 steps	4MB (Includes System Memory): Approx. 35,000 steps
External Storage		PCMCIA Card Slot	FDD
Communication Interface	PC, Network etc.	RS-232C	RS-485, Ethernet (Please contact us.)
	Fieldbus		CC-Link, DeviceNet, PROFIBUS-S, ControlNet, AB Remote I/O (Please contact us.)
Teach Pendant			6.4 in. TFT Color LCD with Touch Panel, 640 × 480 VGA, Emergency Stop SW., Teach Lock SW., Deadman SW. 58 Hard Keys (Robot Manual Operation Keys, Cursor Keys, etc.)
Operation Panel		Basic Switches: Motor Power ON, Cycle Start, Error Reset, Emergency Stop, RUN/HOLD, TEACH/REPEAT, etc.	
Cable Length	Teach Pendant	5 m	10 m, 15 m
	Robot-Controller	5 m	10 m, 15 m
Dimensions		W600 × D550 × H1,200 (mm)	
Weight		Approx. 120kg	Approx. 190kg (with Transformer)
Power Requirements		AC200/220V ± 10%, 50/60Hz, 3-Phase, 11 kVA	AC380/400/415/440V ± 10%, 50/60Hz, 3-Phase, 11 kVA AC440/460/480/515/575V ± 10%, 50/60Hz, 3-Phase, 11 kVA
	Robot Dedicated Grounding	Less than 100Ω max. Leakage Current 100 mA	Less than 100Ω max. Leakage Current 10 mA
Ambient Temperature / Humidity		0-45 °C, 35-85%RH without Condensation	
Color		Munsell 10GY9/1 equivalent	

(Accessories Included) Communication Terminal Software with PC

(Optional Accessories) Teach Pendant Holder, Brake Release SW., Plug for Auto Running without A Teach Pendant, RS-232C Cable (1.5m, 3m), PC Card, etc.  
Other options or Software : Please contact us.

### Communication via system scalability

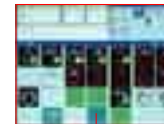

A Customized interface panel screen can be used for the operation of peripherals, providing an alternative interfacing possibility.

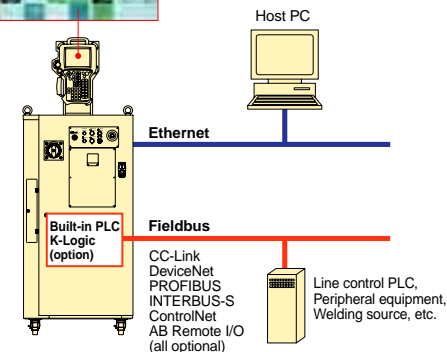

### • External View and Dimensions

